

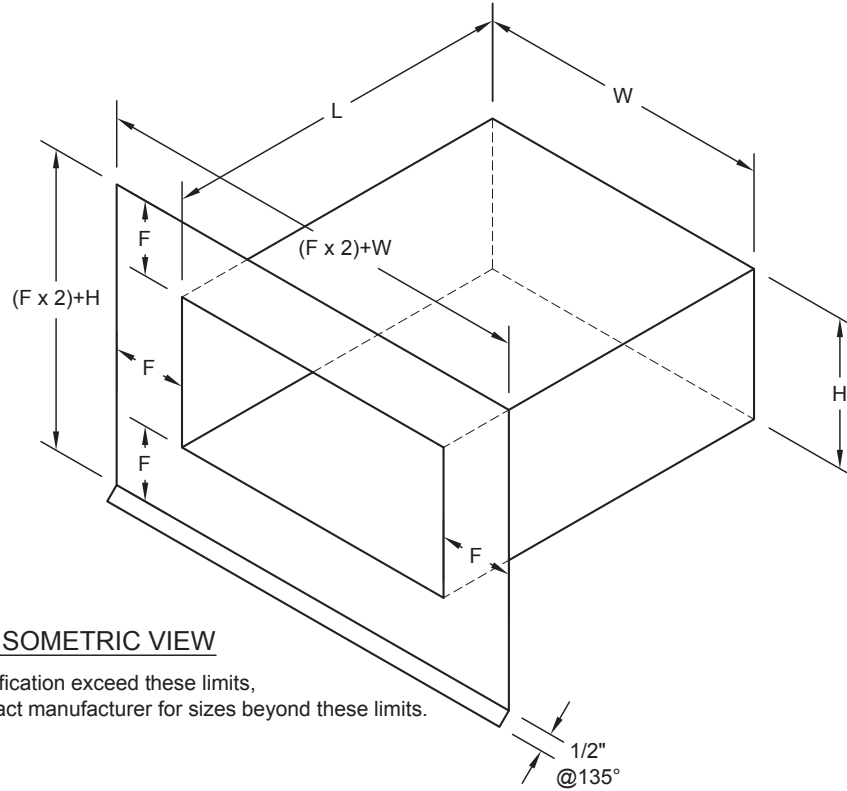

Thru-Wall Scupper

Order Specification Form



QUANTITY	SIZES	MATERIAL	THICKNESS	ACCESSORY TYPE	FINISH
_____ Units	F = _____ (2-in. TYP) H = _____ (8-in. MAX) ① L = _____ (24-in. MAX) ① W = _____ (12-in. MAX) ①	<input type="checkbox"/> Aluminum <input type="checkbox"/> Stainless Steel <input type="checkbox"/> _____	<input type="checkbox"/> 0.050 <input type="checkbox"/> 0.063 <input type="checkbox"/> 16Ga <input type="checkbox"/> _____	<input type="checkbox"/> Welded	<input type="checkbox"/> Mill Finish <input type="checkbox"/> Post Finished Kynar <input type="checkbox"/> Post Finished Anodized <input type="checkbox"/> _____ COLOR <input type="checkbox"/> _____

APPROVALS: Contact manufacturer for verification of test report data on your project.		CUSTOMER APPROVAL	
		<input type="checkbox"/> Approved for Fabrication <input type="checkbox"/> Approved with Changes <input type="checkbox"/> Not Approved	
		_____ Authorized Customer Signature _____ Title Date	
Job Name:	Job #:	By:	
Customer:	Project Location:	Date:	
Representative:	Architect:	Sheet of	



Superior productivity.
Superior performance.

4 COMMERCE WAY, ARDEN, NC 28704 USA
800-892-9173 828-676-1700 OMGEDGESYSTEMS.COM
Copyright © 2017 OMG, Inc. All rights reserved.

